

ATNP/WG-2

WP/209

23 January 1996

AERONAUTICAL TELECOMMUNICATION NETWORK PANEL
WORKING GROUP 2

Brisbane, Queensland, Australia

5-9 February 1996

Tools for ATN Validation Experiments in Germany

Information Paper

prepared by A. Herber

SUMMARY

This paper provides an overview of the systems forming the basis of DFS's ATN test bed and the possible validation areas and invites partners to join DFS's validation activities.

1. Background

- 1.1. DFS is in a position to support the ATN validation activities by establishment of an experimental ATN environment allowing joint experiments on a multilateral basis (e.g. with LVB, Eurocontrol etc.).
- 1.2. An evaluation concept for the ATN activities had been defined and has been adopted by DFS management.
- 1.3. With respect to the ATN system infrastructure, DFS determined to
 - ### put into operation an experimental ATN test bed (comprising two routers and one end system) at the DFS test and evaluation centre (TEZ) in Frankfurt;
 - ### establish a connection to the **public X.25** PSDN of the German Telekom ("Datex-P") allowing interconnection to France Telecom's PSDN ("Transpac") and thus to the EURATN demonstrator and the PHARE ATN;
 - ### establish a connection to DFS's **private X.25** PSDN ("PSN" resp. "RAPNET") allowing e.g. interconnection to LVB's ATN experimental environment or perhaps lateron the Eurocontrol Experimental Centre (EEC);
- 1.4. The foreseen configuration for early 1996 is illustrated as follows:

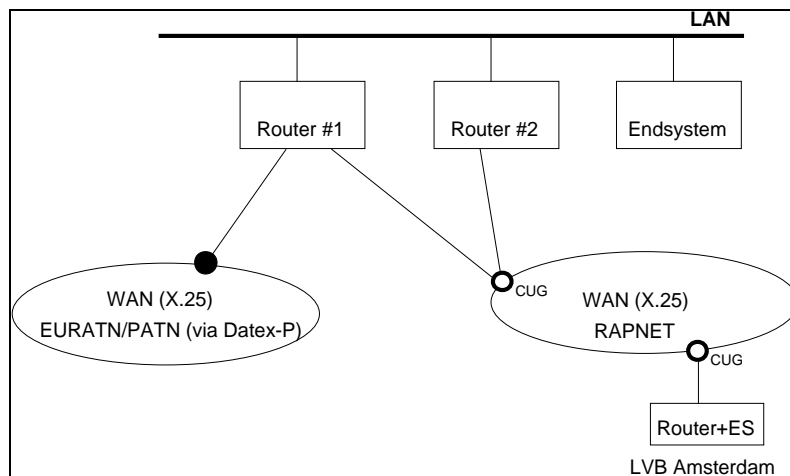
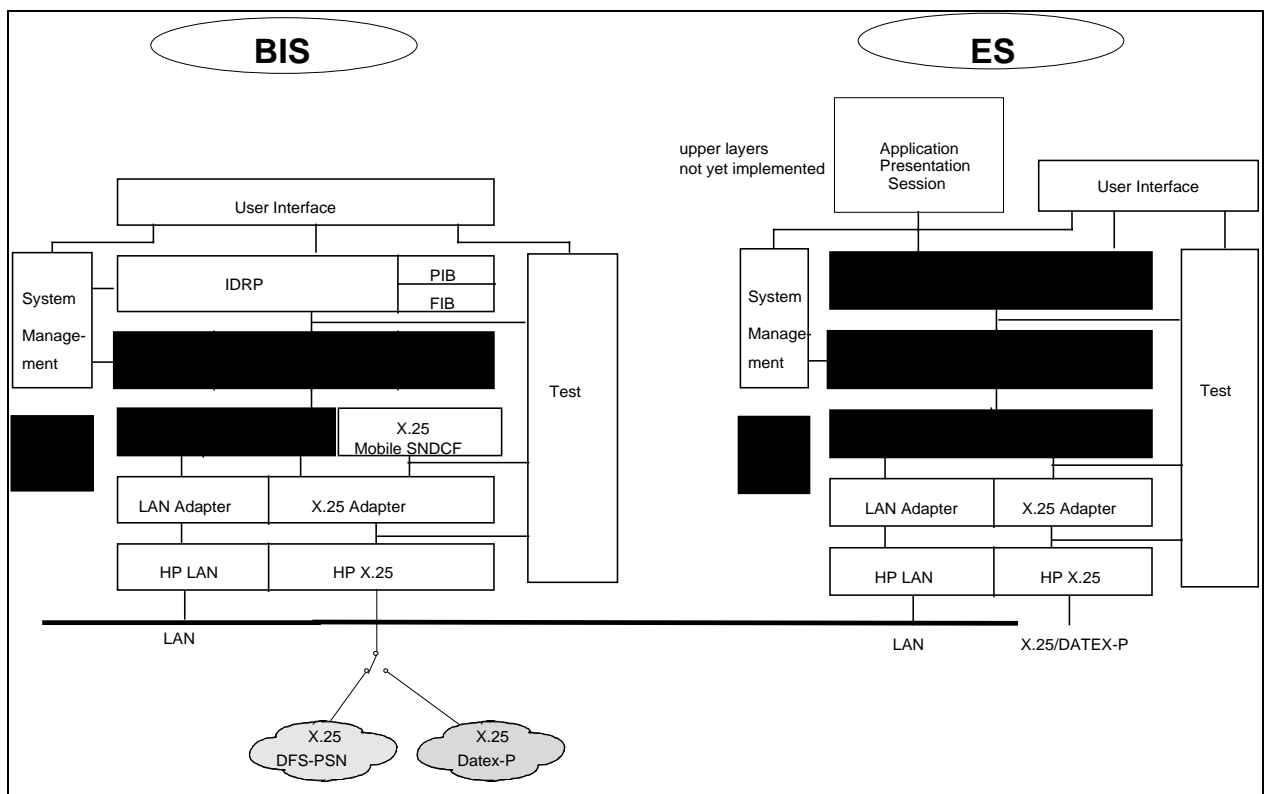

Fig. 1: Initial Configuration of ATN Components at DFS Test Centre

2. Current Status

- 2.1. A contract about the delivery and installation of an experimental ATN test bed comprising the above mentioned three systems at the TEZ has been placed in late September 1995. For a number of reasons, DFS had decided to base the ATN components on DEMISIS systems, which are currently compatible with the ATN manual, version 2. Like for the EURATN systems, onto which the DEMISIS IDRP has been ported, the system will be modified to comply with the CNS/ATM-1 communication requirements. Interoperability tests between EURATN and DEMISIS systems will be performed by Eurocontrol and the EURATN consortium. In conclusion, the DFS systems can be regarded as being compatible with the PATN environment.
- 2.2. The application for two RAPNET access lines has been performed recently, and a closed user group (CUG) had been formed by the RAPNET office in order to protect the operationally used network; currently, the CUG comprises only the two addresses of DFS's ATN routers; however, it is foreseen that the LVB (and later potentially also the EEC) is becoming an additional member of this CUG.

- 2.3. In addition, a German Telekom's Datex-P (X.25 PSDN) access has been established.
- 2.4. During November of last year, the installation of the two routers and their connection to the X.25 WANs was performed. The consecutive acceptance tests followed the Eurocontrol test procedure, plus additional tests with respect to the successful interworking with the X.25 connections provided by DFS. The acceptance tests were successfully passed.
- 2.5. In early December last year, a third DEMISIS system was installed at the TEZ, configured as an end system, including TP4 and a simple transport service interface allowing acceptance testing and access for validation experiments.
- 2.6. Unfortunate is the current conformance of the DFS's ATN systems to the requirements of the ATN Manual, version 2, only. As a consequence, neither the support for non-IDRP equipped aircraft, nor the changed handling of security is available. An upgrade to CNS/ATM-1 package compliance is planned for this year, but independently of this, a number of further validation experiments can be performed. In particular, first interoperability tests between the BISs installed at DFS's TEZ and CNS/ATM-1 package compliant BISs can be performed without using the security attribute.
- 2.7. A block diagram showing the main elements of DFS's ATN router and end system is given in the figure below.



- 2.8. A form describing the characteristics of the data communication components available is given as attachment 1.

3. Near term plans

- 3.1. The successful connection of DFS's test environment to other partners via both, the RAPNET and the public PSDN, will be an activity for the first months of 1996. In this context, it would be of great interest to DFS to identify those partners which are in a position to join these internetworking activities (in the beginning, preferred partners would be those to which connections via Datex-P can be established as well).
- 3.2. Consequently, the foreseen SARPs validation activities, offered for consideration in the working group, will be concentrating on
 - ### Interoperability tests;
 - ### Performance and verification tests over real X.25 subnetworks, taking into account specifics of potentially different service providers;
 - ### Routing consistency and efficiency tests involving several remote ATN BIS systems;
 - ### Verification of specific Routing Policies ?
- 3.3. Generally, DFS is interested in performing validation exercises demonstrating the feasibility of ATN/ATM applications.
- 3.4. Furthermore, DFS plans to support SARP's validation through simulation exercises using the OPNET simulation environment. The main objectives of these simulation exercises are:
 - ### to analyse and to evaluate large scale ATN behaviour;
 - ### to validate consistency and completeness of ATN routing policies;
 - ### to determine ATN network traffic loads; and
 - ### to identify feasible and attractive network topologies.

4. Summary

- 4.1. DFS is expecting to provide very soon the technical infrastructure of a prototype ATN test bed, providing access to both, PATN as well as RAPNET, and an ATN evaluation environment at the DFS test and evaluation centre in Frankfurt.
- 4.2. DFS is offering to perform joint experiments in the area of ATN validation and is generally very much interested also in demonstrations of the feasibility of ATN/ATM applications.

Attachment A: Description of Validation Tools used by DFS

Tool Identification	
Name	DEMISIS
Full Name	DEMISIS (Development/Modification of ISO 10747, ISO 8473 and the SNDCF for ISO 8208 Subnetworks)
Category	PROTOTYPE IMPLEMENTATION
Description	<p>DEMISIS is a configurable ATN Intermediate System/ End System. It can be configured to operate as various types of ATN routers (see below) and End Systems. This release conforms to the ATN Manual 2.0, but currently does not comply to the Draft CNS/ATM-1 SARPs. The upgrade is planned for 1996.</p> <p>DEMISIS was developed by ESG for EUROCONTROL.</p>
Contact Point and/or Supplier	DFS Deutsche Flugsicherung Dr. Andreas Herber Tel: +49 69 6335 263 Fax: +49 69 6335 219 Email: herber@se.dfs.com
Tool Version and Date	Release dfs-1.1a-TP4, 951123
Supporting Hardware	HP 9000/700 series
Supporting Operating System and/or Software	HP-UX 9.0
CNS/ATM-1 SARPs Scope	
ATN Systems	#### End System #### Intra-domain Intermediate System #### Ground-ground BIS #### Air-ground BIS #### Airborne BIS
Protocols	#### ISO 8073 #### ISO 8602 #### ISO 8473 #### ISO 9542 #### ISO 10747 #### ISO 8802 SNDCF #### ISO 8208 SNDCF #### ISO 8208 Mobile SNDCF Other: ISO 10589
CNS/ATM-1 Specifics	#### ATN Addressing #### ATN Routing Policy #### Air-Ground Route Initiation (currently, only ATN Manual compliant) #### ATN Priority #### ATN Security

Connectivity Information		
Type	Connector Type and Number	Notes
ISO 8802-3 LAN	As per workstation configuration	
X.25	As per workstation configuration	
Notes		
compliant with ATN manual 2; foreseen to be upgraded to conform to Draft CNS/ATM-1 SARPs		